

VTA-7100T

10.4" SVGA Windows® CE-based SCADA HMI



- | | |
|---------------------------|---------------------|
| 1. Power switch (AT) | 5. COM 2 (RS-232) |
| 2. 24 VDC power | 6. Ethernet |
| 3. VGA | 7. USB 2.0 x 2 |
| 4. COM 1 (RS-232/422/485) | 8. Audio (Line-out) |

Features



- 10.4" SVGA (800 x 600) color TFT LCD
- Fanless cooling system with AMD LX800 processor onboard
- Supports complete PLC drivers & OPC client
- Remote monitoring by Web browser
- Standard Windows ODBC/SQL database
- Comprehensive graphical components
- Easy-to-expand: MiniPCI

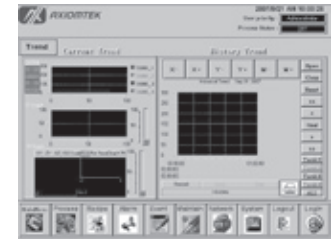

WinPC32 Pro

Introduction

The VTA-7100T is a 10.4" fanless HMI equipped with Web-based SCADA software, WinPC32 Pro run-time. It adopts AMD LX800 500 MHz processor and fanless cooling system. With WinPC32 Pro run-time, the VTA-7100T can easily connect to different type of PLCs, and also connect PC-based I/O modules. Besides, on the platform of Windows® CE, the VTA-7100T greatly improves the problems such as OS compatibility, hardware expansion, operating function and storage performance. Thus, the VTA-7100T is the newest generation HMI solution for factory automation, machine maker and semi-conductor industry.

Complete PLC drivers

Driver library includes the communication drivers of all major brands such as Rockwell, Siemens, GE Fanuc, Modicon, Omron, Mitsubishi, Panasonic and Fuji PLCs, DCS, temperature controller, etc.

Remote monitoring by Web browser

The HMI software is Web browser-enabled that operators may

monitor, upload and analyze the status of the entire application through internet.

Comprehensive graphical components

The HMI software, WinPC32Pro, provides users with a convenient way to build their own application programs. It allows users to import GIF, BMP and graphic objects and even composes their own custom components as a standard one for future use.

OPC client & ODBC/SQL supported

The VTA series is built in OPC client to link with equipments with the OPC server. It allows VTA series to connect third party device such as remote I/O modules, PLC and more. Besides, VTA series is capable of linking to remote plant level data base to download recipes or upload process record and logs.

Specifications

Front Bezel	IP65, NEMA 4 rugged protection, plastic front bezel	
LCD Panel	10.4" SVGA TFT LCD	
	Brightness (cd/m ²)	230 nits
	Resolution	800 x 600
	Viewing Angle (H/V)	120° / 100°
Main System	CPU	AMD LX800 500 MHz
	Chipset	AMD LX+CS5536AD

System Memory	1 x DDR SODIMM min. 256MB, max. up to 1GB
BIOS	Award 4Mbit with RPL/PXE LAN Boot ROM, SmartView and customer CMOS backup
Storage	1 x CompactFlash™
Watchdog Timer	255 levels, 0-255 sec.
Onboard Graphics	Integrated in AMD LX

IO Connector	1 x RS-232 (COM 2) 1 x RS-232/422/485 (COM 1) 2 x USB 2.0 1 x 10/100Mbps Ethernet 1 x Audio (Line-out) 1 x VGA
Expansion Interface	1 x MiniPCI slot
Touchscreen	Resistive type
Power Supply	24VDC w/ fuse over-current protection, 55W
Dimensions	293mm (11.53") (W) x 44.6mm (1.76") (D) x 236mm (9.29") (H)
Weight (net/gross)	1.6 kg (3.52 lb)/2.8 kg (6.17 lb)
Certification	CE
Environmental	Operation temperature: 0°C - +45°C (32°F - 113°F) Relative humidity: 10% - 95% @ 40°C; non-condensing Operation vibration: (w/o expansion) 2.0G, 5 - 500Hz, random for CompactFlash™

Ordering Information

VTA-7100T	10.4" SVGA Windows® CE-based SCADA HMI with WinPC 32 Pro run-time & Windows® CE license
50966A23020E	Power adapter, 72W, 110-230V _{ac} to 24V _{dc}
WinPC32 Pro builder	

*Specifications and certifications are limited to optional.

**Users need WinPC32 Pro builder for programming.

Dimensions

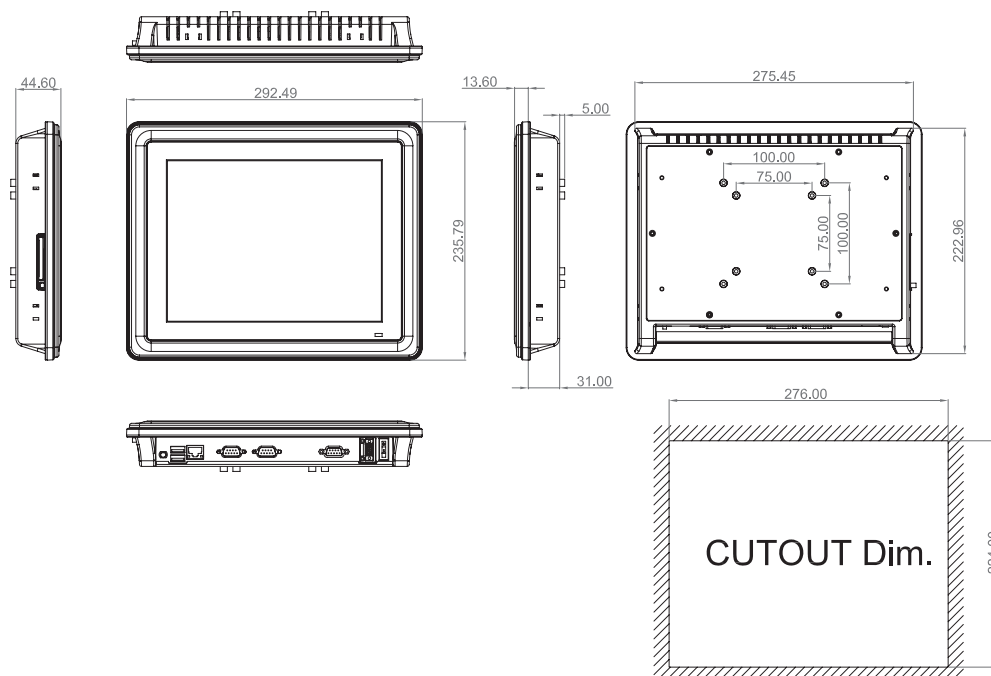

Optional EOS Installation

Windows® CE.NET



Side view

Touch Panel Computers for Various Industry Applications

Digital Signage and Display Solutions

Medical Panel Computers

Medical Grade Monitors

GOT Fanless Touch Panel Computers

Touch Panel Computers for Infotainment

Touch Panel Computers for Automation

Touch Panel Monitors for Automation

Touch Panel Computers with HMI Software